

# ALUMINUM COMPATIBLE LASER WELDABLE SUB-D CONNECTOR

- TRADITIONAL CONFIGURATION WITH THE FLANGE LOCATED AT THE MIDSECTION OF THE CONNECTOR
- DESIGNED TO LASER WELD INTO AN ELECTRONIC CHASSIS WALL
- CONFORMS TO MIL-DTL-24308 (SIZE 20 CONTACT) AND ARE AVAILABLE IN 9, 15, 25, 37, AND 50 COUNT CONTACT CONFIGURATIONS.
- INCORPORATES BERYLLIUM-COPPER CONTACTS INDIVIDUALLY SEALED USING CERAMAX® PROPRIETARY CERAMIC TO ESTABLISH A DURABLE HERMETIC SEAL.
- THE INTERNAL PINS CAN BE CONFIGURED TO ACCEPT INSULATED WIRE, AUTOMATIC WIRE BONDS, RIBBON WELDS, OR SOLDER CONNECTIONS.

1. LEAK RATE: LESS THAN OR EQUAL TO 1X10E-9 CC/SEC He AT ONE ATMOSPHERE DIFFERENTIAL PRESSURE.
  2. INTERFACE AND MOUNTING HOLES IN ACCORDANCE WITH MIL-DTL-24308/2.
  3. MATERIALS:  
 CONTACT: BERYLLIUM-COPPER ALLOY 172/173 IN ACCORDANCE WITH ASTM B196/197.  
 INSULATOR: CERAMAX PROPRIETARY CERAMIC.  
 WELD FLANGE: ALUMINUM ALLOY 4032 IN ACCORDANCE WITH ASTM B247.  
 THREADED INSERTS: IN ACCORDANCE WITH NAS 1130-04-15.
  4. FINISH:  
 CONTACTS: NICKEL PLATE PER QQ-N-290, .000100/.000250 THICK.  
 GOLD PLATE PER ASTM B488, TYPE III, CODE A, .000050/.000100 THICK.  
 PLATE ENTIRE EXPOSED PIN, BOTH ENDS.
- SHELL: CHEMICAL CONVERSION COAT IN ACCORDANCE WITH MIL-C-5541, CLASS 1A.
5. ORDERING INSTRUCTIONS:  
 SPECIFY BASE NUMBER FOLLOWED BY DASH NUMBERS INDICATING PIN COUNT AND CONFIGURATION (SEE SHEET 2):

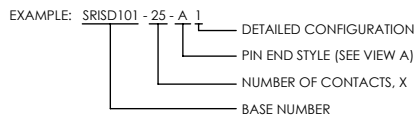

REVISIONS			
REV	DCN	REVISION DATE	RELEASE APPROVAL
-	INIT RLSE	----	/s/ dc
A	DCN000008	8/9/2004	/s/ dc
B	DCN000083	7/7/2005	JP
C	DCN000395	12/18/2008	J. PETRI
D	DCN001657	12/4/2015	J. PETRI
E	DCN001788	7/15/2016	J. PETRI
F	DCN001879	11/16/2016	J. PETRI
G	DCN001910	1/31/2017	J. PETRI
H	DCN002011	10/17/2017	

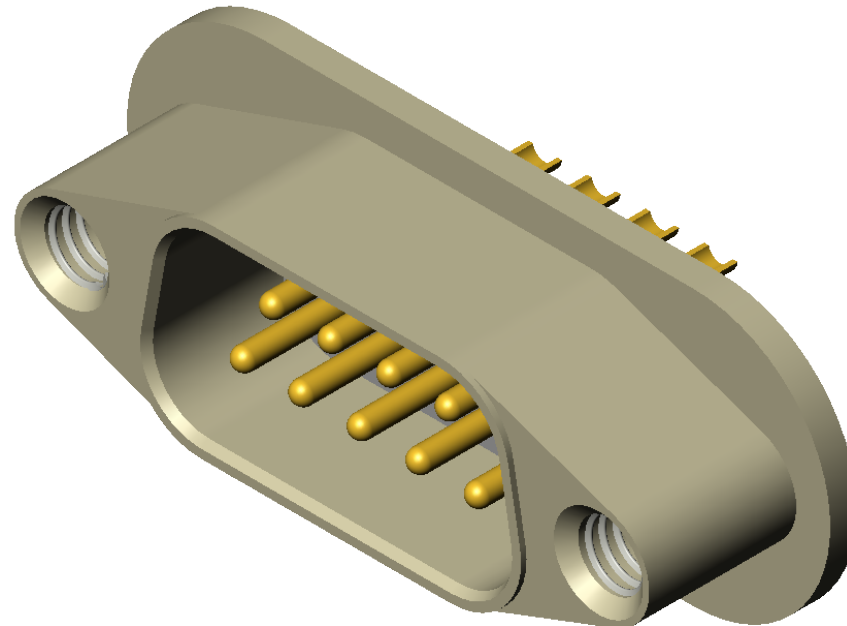

DIMENSIONING IAW ASME Y14.5M-1994 DIMENSIONS APPLY AFTER PROCESSES DIMENSIONS IAW US CUSTOMARY UNITS X ± .1, XX ± .01, XXX ± .005, <math>\angle \pm .5^\circ</math> .010 MAX OUTSIDE R, .005 MAX INSIDE R 63 RMS SURFACE FINISH THIRD ANGLE PROJECTION 		(321) 254-4067 www.srihermetics.com	
TITLE CONNECTOR, SUB-D, MID FLANGED, ALUMINUM COMPATIBLE LASER WELDABLE		SIZE DOCUMENT SRISD101 REV H	
DO NOT SCALE DRAWING		SCALE 2:1	SHEET 1 OF 3

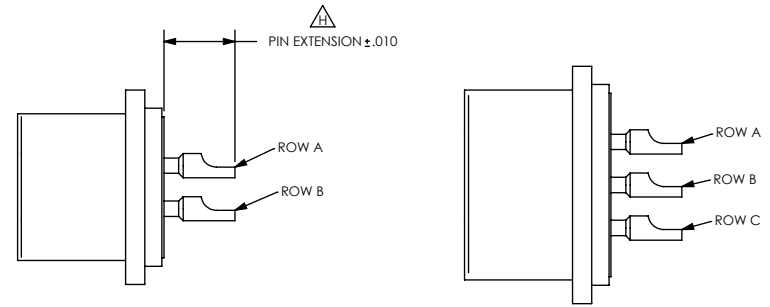
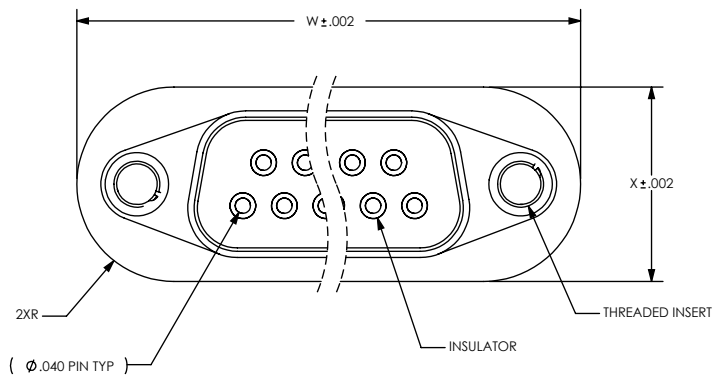

9-37 PIN CONFIGURATIONS

50 PIN CONFIGURATION

PIN EXTENSIONS (SEE SH 3)

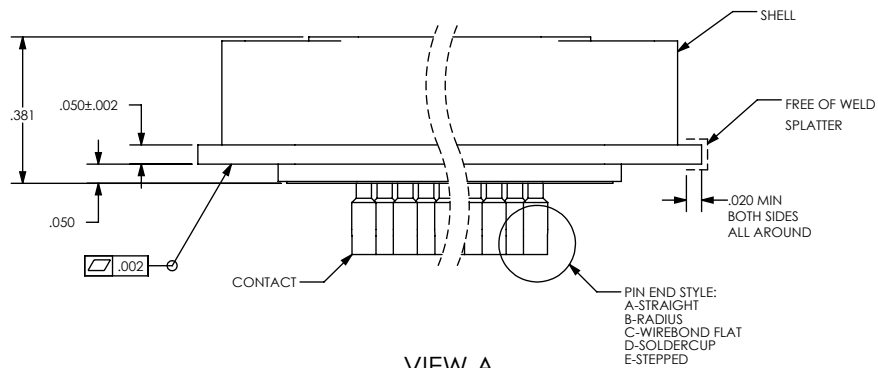

VIEW A

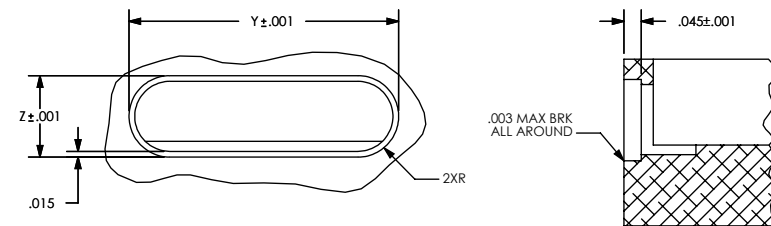

SUGGESTED HOLE DETAIL

NUMBER OF CONTACTS	W	X	Y	Z
9	1.297	0.506	1.300	0.509
15	1.625	0.506	1.628	0.509
25	2.165	0.506	2.168	0.509
37	2.814	0.506	2.817	0.509
50	2.720	0.618	2.723	0.621

DIMENSIONING IAW ASME Y14.5M-1994  
 DIMENSIONS APPLY AFTER PROCESSES  
 DIMENSIONS IAW US CUSTOMARY UNITS  
 X ± .1, XX ± .01, XXX ± .005, ∠ ± .5°  
 .010 MAX OUTSIDE R, .005 MAX INSIDE R  
 63 RMS SURFACE FINISH  
 THIRD ANGLE PROJECTION



DO NOT SCALE DRAWING



(321) 254-4067  
 www.srihermetics.com

TITLE CONNECTOR, SUB-D, MID FLANGED,  
 ALUMINUM COMPATIBLE LASER WELDABLE

SIZE A	DOCUMENT	SRISD101	REV H
SCALE 2:1	CAGE CODE 3PJY7	SHEET	2 OF 3

8 STRAIGHT PIN END STYLE, A

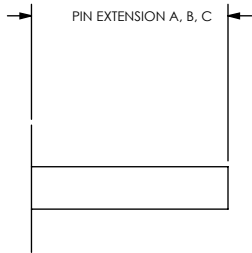

PART NUMBER	A	B
SRISD101 - X - A1	.345	.345

7 RADIUS PIN END STYLE, B

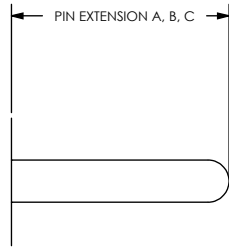

PART NUMBER	A	B
SRISD101 - X - B1	.360	.360

5 WIREBOND FLAT PIN END STYLE, C

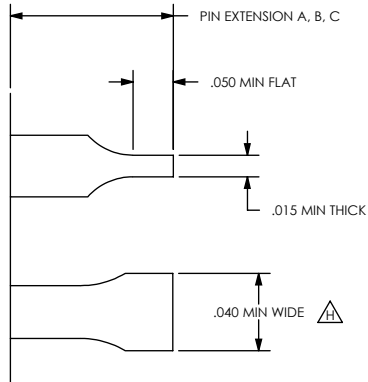

PART NUMBER	A	B
SRISD101 - X - C1	.140	.205



4 SOLDERCUP PIN END STYLE, D

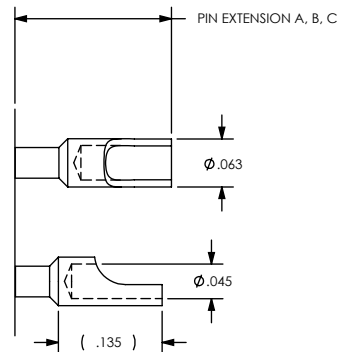

PART NUMBER	A	B	C
SRISD101 - X - D 1	.185	.185	.185



2 STEPPED PIN END STYLE, E

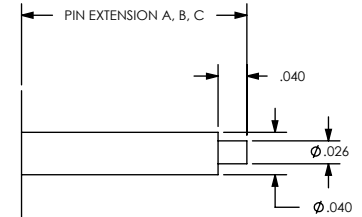

PART NUMBER	A	B	C
SRISD101 - X - E 1	.105	.105	.105

D

C

B

A

D

C

B

A

DIMENSIONING LAW ASME Y14.5M-1994  
 DIMENSIONS APPLY AFTER PROCESSES  
 DIMENSIONS LAW US CUSTOMARY UNITS  
 X ± .1, XX ± .01, XXX ± .005, < 5°  
 .010 MAX OUTSIDE R, .005 MAX INSIDE R  
 63 RMS SURFACE FINISH  
 THIRD ANGLE PROJECTION



DO NOT SCALE DRAWING



(321) 254-4067  
 www.srihermetics.com

TITLE CONNECTOR, SUB-D, MID FLANGED,  
 ALUMINUM COMPATIBLE LASER WELDABLE

SIZE DOCUMENT SRISD101 REV H

SCALE 2:1 CAGE CODE 3PJY7 SHEET 3 OF 3