

# ALUMINUM COMPATIBLE LASER WELDABLE 7-PIN HEADER

REVISIONS			
REV	CHANGE NO.	DATE	CFG APPROVAL
-	INIT RLSE	04-28-2009	J. PETRI

- CONFIGURATION WITH THE WELD LIP LOCATED AT THE TOP OF THE CONNECTOR
- DESIGNED TO LASER WELD INTO AN ELECTRONIC CHASSIS WALL
- INCORPORATES BERYLLIUM-COPPER CONTACTS INDIVIDUALLY SEALED USING CERAMAX® PROPRIETARY CERAMIC TO ESTABLISH A DURABLE HERMETIC SEAL.

- HERMETIC LEAK RATE: LESS THAN OR EQUAL TO  $1 \times 10^{-9}$  CC/SEC He AT ONE ATMOSPHERE DIFFERENTIAL PRESSURE.
- INSULATION RESISTANCE: GREATER THAN 5,000 MEGOHMS AT  $500 \pm 10\%$  VDC AT 25°C IN ACCORDANCE WITH MIL-STD-1344, METHOD 3003.
- DIELECTRIC WITHSTANDING VOLTAGE: NO EVIDENCE OF BREAKDOWN OR FLASHOVER AT 600 VAC RMS (60Hz) IN ACCORDANCE WITH MIL-STD-1344, METHOD 3001. DURATION OF APPLICATION SHALL BE 1 SECOND MINIMUM.
- MATERIALS:  
CONTACT: BERYLLIUM-COPPER ALLOY 172/173 IN ACCORDANCE WITH ASTM B196/197.  
INSULATOR: CERAMAX PROPRIETARY CERAMIC.  
WELD FLANGE: ALUMINUM ALLOY 4047 IN ACCORDANCE WITH AWS A5.8.
- FINISH:  
CONTACTS: NICKEL PLATE PER QQ-N-290, CLASS 1, .000100 / .000250 THICK.  
GOLD PLATE PER ASTM B488-01, TYPE III, CODE A, .000050 / .000100 THICK.  
PLATE ENTIRE EXPOSED PIN, BOTH ENDS.
- ORDERING INSTRUCTIONS:  
SPECIFY PART NUMBER SRIMP102 - 1

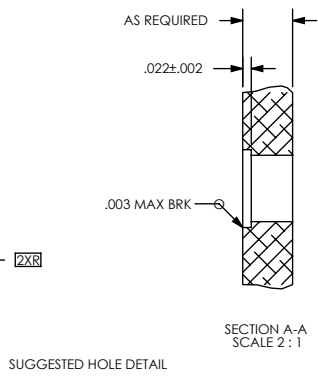
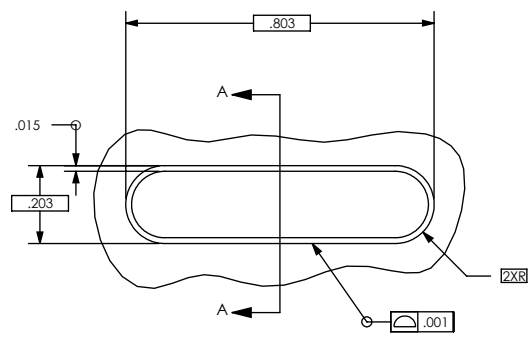
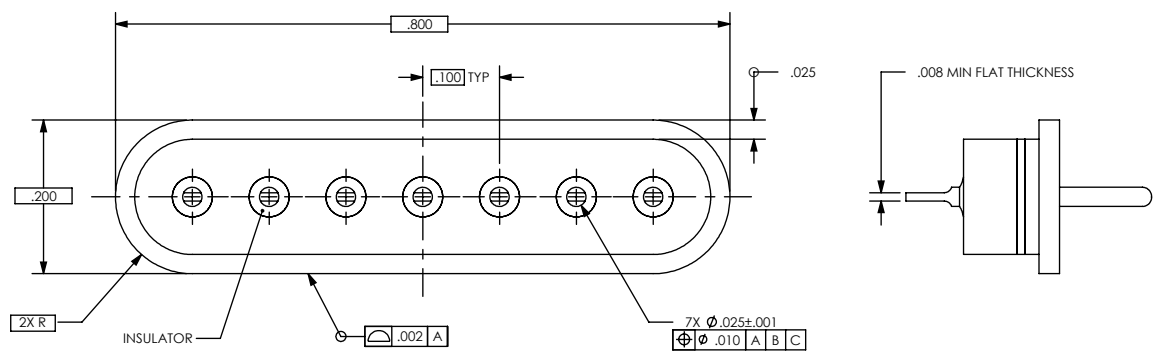
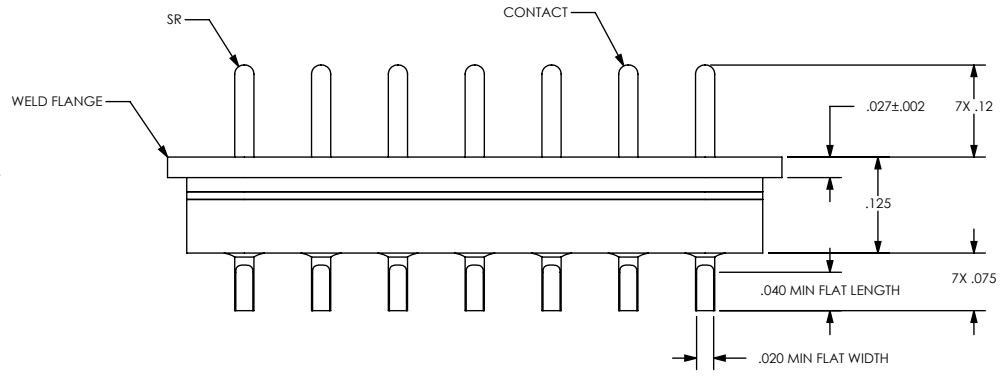

UNLESS OTHERWISE SPECIFIED		(321) 254-4067 WWW.SRIHERMETICS.COM	
DIMENSIONING IAW ASME Y14.5M-1994 DIMENSIONS APPLY AFTER PROCESSES DIMENSIONS IAW US CUSTOMARY UNITS .X ± .1, .XX ± .01, .XXX ± .005, ∠ ± .5° .010 MAX OUTSIDE R, .005 MAX INSIDE R 125 RMS SURFACE FINISH		TITLE CONNECTOR, 7-PIN AC LBW	
SIZE A	DOCUMENT SRIMP102	REV -	
SCALE 4:1	CAGE CODE 3PJY7	SHEET 1 OF 1	